

INPUT	IA5Q	IM5Q	IN5Q	Units
Nominal Input Voltage	120	240	24/48	Vrms/Vdc
Minimum Input Voltage	90	180	10	Vrms/Vdc
Maximum Input Voltage	140	280	60	Vrms/Vdc
Maximum Input Current*	10	8	30	mA rms
Drop Out Current	2.5	1.5	1.0	mA rms
Allowable Off-state Current	3.0	2.0	1.0	mA rms
Allowable Off-state Voltage	50	120	2	Vrms/Vdc

OUTPUT	IA5Q	IM5Q	IN5Q	Units
Nominal Logic Supply Voltage	5.0	5.0	5.0	V dc
Minimum Logic Voltage	4.5	4.5	4.5	V dc
Maximum Logic Voltage	6.0	6.0	6.0	V dc
Typical Logic Supply Current*	10	10	10	mA dc
Max. Logic Supply Current**	14.5	14.5	14.5	mA dc
Max. Logic Sup. Leak. Current**	20	20	20	$\mu$ A dc
Maximum Output Voltage	30	30	30	V dc
Maximum Output Current	50	50	50	mA dc
Max. Output Leakage Current**	20	20	20	$\mu$ A dc
Max. Output Voltage Drop†	200	200	200	mV dc
Maximum Turn-on Time (ac)	20	20	20	msec
Maximum Turn-off Time (ac)	30	30	30	msec
Maximum Turn-on Time (dc)	1	1	1	msec
Maximum Turn-off Time (dc)	1	1	1	msec

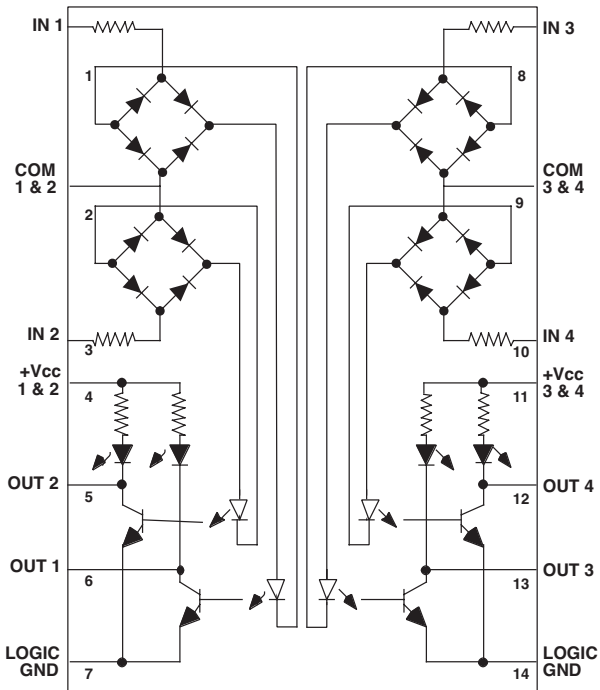

• Infrared Coupler LED  
 • Red Indicator LED  
 • Equivalent Circuit Only  
 • Negative True Logic

\* @ nominal voltage  
 \*\* @ maximum logic voltage  
 † @ maximum output current

**General specifications**

Operating temperature range -30 to +80°C  
 Storage temperature range -40 to +100°C  
 Isolation 4,000 V rms  
 Capacitance input to output 8 pF  
 Line frequency range 47 to 63 Hz

\* @nominal input voltage (ac)

**Application notes**

- Do not install or remove modules in live (electrically hot) circuits. High voltage may be present.
- Input connections are non-polarized.
- The controlled voltage on the output pins (OUT 1,2,3, and 4) cannot exceed 3 V dc higher than +Vcc. This is a limitation of the reverse breakdown voltage of the status indicator LED's.
- An externally located diode (forward biased) can be installed in series with +Vcc 1 & 2 (pin 4) or +Vcc 3 & 4 (pin 11) of the module to extend the output control voltage to a maximum of 30 V dc. An externally located diode (forward biased) can be installed in series with the + terminal of a quad backplane to extend the output control voltage to a maximum of 30 V dc.