

WRC-CANR-DF-DN
Series 3
CAN-Bus Fiber Optic Bus Extender
User's Manual



Western Reserve Controls, Inc.

Although every effort has been made to insure the accuracy of this document, all information is subject to change without notice. WRC takes no liability for any errors in this document or for direct, indirect, incidental or consequential damage resulting from the use of this manual.

Document PUB 14.1
Rev 3.00
March 2003

Copyright © 1998-2003 WRC

Western Reserve Controls, Inc.

1485 Exeter Road
Akron OH 44306
330-733-6662 (Phone)
330-733-6663 (FAX)
sales@wrcakron.com (Email)
<http://www.wrcakron.com> (Web)

SmartMux-Lite, CAN-Bus Extender and WRC are trademarks of Western Reserve Controls, Inc.
DeviceNet is a trademark of the Open DeviceNet Vendor Association, Inc. ("ODVA").
SDS is a trademark of the Honeywell, Inc.
All other trademarks are property of their respective companies.

TABLE OF CONTENTS

1. OVERVIEW	1
1.1. SERIES 3 SPECIFIC FEATURES	1
1.2. FEATURES.....	2
1.3. BASIC OPERATION	2
1.4. REFERENCE DOCUMENTS.....	3
2. QUICK START.....	4
3. GENERAL SPECIFICATIONS	5
4. HARDWARE INSTALLATION AND CONFIGURATION.....	6
4.1. OVERVIEW	6
4.2. LED OPERATION	6
4.3. DIP SWITCH SETTINGS	8
4.4. POWER REQUIREMENTS.....	9
4.5. CAN NETWORK CABLING AND CONFIGURATION.....	9
4.5.1. Cable Lengths.....	9
4.5.2. Network Termination	9
4.5.3. CAN-Bus Connection Wiring	10
4.5.4. Alternate Connector Options.....	12
4.6. FIBER CABLE.....	12
5. OPERATION.....	13
5.1. APPLICATION NOTES.....	13
6. ACCESSORIES AND OTHER WRC PRODUCTS	15
7. TROUBLESHOOTING.....	17
8. SUMMARY OF CHANGES TO SERIES 3 FROM REV 2	19
8.1. DIP SWITCH BAUD RATE SETTINGS	19
8.2. INDICATOR LED'S.....	19
8.3. TERMINATING RESISTORS.....	19
8.4. OPERATION AND FUNCTIONALITY.....	19
8.5. 2.2KM FIBER LINK AND DIAGNOSTICS.....	19
8.6. ENHANCED CAN SUPPORT	20
8.7. FIELD PROGRAMMABLE UPDATES.....	20

LIST OF TABLES

TABLE 4-1 MODULE STATUS LED (LABELED MS).....	7
TABLE 4-2 LOCAL DEVICE'S NETWORK STATUS LEDS (LABELED NSA).....	7
TABLE 4-3 REMOTE DEVICE'S NETWORK STATUS LEDS (LABEL NSB).....	7
TABLE 4-4 DIAGNOSTIC STATUS LEDS (LABELED DNG).....	8
TABLE 4-5 BAUD RATE SETTINGS FOR SWITCHES.....	8
TABLE 4-6 NETWORK MAXIMUM LENGTHS - DEVICENET.....	9
TABLE 4-7 NETWORK MAXIMUM LENGTHS - SDS.....	9
TABLE 4-8 TERMINATING RESISTORS.....	10
TABLE 4-9 DEVICENET CABLE SPECIFICATIONS.....	11
TABLE 4-10 SDS CABLE SPECIFICATIONS.....	12
TABLE 6-1 ACCESSORIES AND OTHER WRC PRODUCTS.....	16

LIST OF FIGURES

FIGURE 1-1 TYPICAL FIBER OPTIC BUS EXTENSION APPLICATION.....	3
FIGURE 4-1 WRC-CANR-DF-DN CAN-BUS EXTENDER.....	6
FIGURE 4-2 DEVICENET NETWORK SIDE A CABLE CONNECTOR – MALE (PINS).....	11
FIGURE 4-3 SDS MINI CONNECTOR.....	11
FIGURE 5-1 CANR-DF ON A DROP LINE.....	14
FIGURE 5-2 CANR-DF ON MULTIPLE DROP LINES.....	14

1. Overview

The WRC-CANR-DF Fiber Optic CAN Bus Extender converts a copper cable medium CAN-Bus network to a fiber optic medium. The WRC-CANR-DF-DN is always used in pairs and, along with the fiber optic cable set, inserts a length of fiber media into the copper CAN Bus network. The primary purposes of this type of configuration is to extend the maximum length defined for one continuous network cable bus up to 2.2km and to provide network protection from external, high-energy electrical interference, such as lightning storms, arc welders, etc. They can be connected in a bus trunk line or drop line.

A WRC-CANR can be used for quite a number of helpful purposes, including

- To provide an electrically-isolated fiber transmission segment to your CAN bus for more secure network in high-energy environmental conditions
- to extend the network beyond its absolute maximum length (e.g., up to 2200 meters additional length) at the slowest speed
- to implement a longer network for a given baud rate (e.g., pushing a 500K baud network beyond 100 m for DeviceNet)
- to provide higher speed baud rates for a given network length
- to extend the length of the drop cable (e.g., longer drops than 6 m for DeviceNet)
- to provide 2600V electrical isolation between the 2 sub-nets
- to create a unique network topology instead of a conventional bus structure, such as a star configuration

The Extenders are transparent to the other nodes on the bus. They receive and actively re-transmit (store-and-forward) each message received at either side of the network without interpreting the message or acting upon it. The Fiber Extenders perform all appropriate CAN Bus arbitration on the copper bus as it re-transmits the message.

The WRC-CANR-DF-DN is a member of WRC's family of products that extend the system communications lengths for DeviceNet, CANopen, SDS (Smart Distributed System) and other CAN, V2.0, Part A or Part B, serial bus systems. By allowing the user to extend the bus length for any given speed, they assist the user in cost-effectively implementing I/O or other nodes on these buses at remote locations that would be more difficult or more expensive to do otherwise.

The unit derives its power through the copper network connector on Side A.

1.1. *Series 3 Specific Features*

The Series 3 CANR provides enhancements over previous versions. Enhancements include:

- Up to 2.2 km fiber lengths
- CAN 2A and 2B, and remote frame, support
- Up to 1M Baud CAN bus operation available
- Enhanced Autobaud operation
- Either unit in a pair can Autobaud from the other units defined baud rate

- Jumper-selectable terminating resistor on-board the CANX
- Increased message internal buffers – Automatic Memory Technology (AMT) operation
- Eliminates the distinction between WRC's earlier version Type 1 and Type 2 CANR's

1.2. Features

The WRC-CANR-DF-DN has the following features:

- Extends CAN-Bus cable lengths - trunk line or drop lines
- Expands the usable applications for CAN-Bus systems
- Allows operation at higher speeds for specific distances
- Provides superior electrical interference protection to copper cables
- Operates at 125K, 250K, 500K and 1M baud
- Switch-selectable Autobaud or fixed baud rate operation
- Automatic speed selection - no configuration required
- Isolates the two sections of the copper bus
- Transparent to the Master and Slave devices on the bus
- No address selection needed
- No configuration parameters
- DeviceNet; SDS; CAN, V2.0, Part A and Part B compatible
- Powered from the 24Vdc supplied by bus network or the user
- Sealed NEMA-4X enclosure
- Standard round, mini-style connector with male pins for copper cable
- Standard Fiber Optic ST female connector, 62.5/125um technology
- Standard CAN chips manage bus error detection
- Standard CAN chips handle message bus contention
- Less than 100 μ sec latency
- Jumper-selectable termination built in on cable side
- 4 bi-color (red/green) status LEDs
- 2 green fiber transmit and receive LEDs

1.3. Basic Operation

Two CANR-DF units are required for each application – both units are identical. It does not matter which is placed in which position with respect to the network topology or other devices on the network.

There are two bus connections for each CANR-DF, referred to as the Copper Cable Network Side (Side A) and Fiber Cable Network Side (Side B). The CAN Bus copper cable is connected to side A of the CANR-DF receives its power from side A.

Figure 1-1 shows a typical application.

Whenever a message is transmitted on the Bus to which CANR-DF is connected, CANR-DF receives the message on the side where it was initiated and performs a store-and-forward of the message to the other side. This action is performed in each direction and is performed for any valid CAN message independent of who generated it or to whom it is intended.

There is approximately a 75 μ sec propagation delay of the message through the CANR-DF.

The CANR-DF is not addressed as a specific device on the Bus and cannot be interrogated by other nodes. It is transparent to all other nodes on the bus.

Fiber-optic extenders - especially useful for outdoor applications

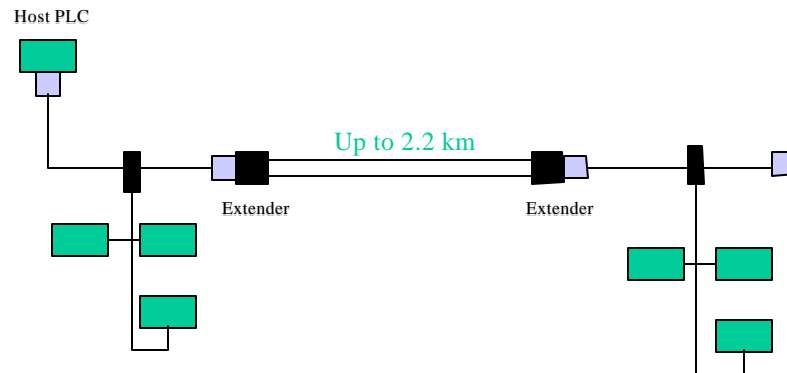

Figure 1-1 Typical fiber optic bus extension application

1.4. Reference Documents

The following documents are referenced in this User's Manual

- ODVA DeviceNet Specification Volume I, Release 2.0
- Honeywell Micro Switch Specification GS 052 104, "SDS Smart Distributed System Physical Layer Specification", release date 12/8/1994

2. Quick Start

To quickly and easily install your CAN-Bus Fiber Optic Extenders in your DeviceNet system, follow the instructions below. For more details, see Section 4.

1. These units are used in pairs. You need **two (2) CANR-DF** units and **two (2) 62.5/125, multi-mode fiber cable lengths**, terminated with **ST male connectors**.
2. Set the baudrate of each CANR-DF to **Autobaud** by setting the switches on the 8-position switch block **SW1** to **all OPEN**.
3. Using on-board jumper W1, terminate CAN-Bus network, as appropriate. (This is especially critical at the higher baud rates.)
 - **For trunk lines, install W1.**
 - **For drop lines, remove W1.**
4. **Connect the fiber cables** to the CANR of one unit. Make sure they are clearly marked on both ends to differentiate between the two lines.
5. Make sure that there is power on the CAN-Bus Network and **plug the Network cable with a 5-pin round female MINI connector** into the CAN-Bus Extender.
6. The CANR-DF Extender will undergo its initialization sequence, flashing the LEDs. After approximately 5 seconds, the Module Status LED (labeled "MS") will go on solid green and network LEDs (labeled "NSA" and "NSB") will flash green.
7. **Repeat steps 2-6 above for the second CANR-DF.**

Note: Be sure to connect the fiber from the TX port on one device to the RX port on the other.
8. Connect the desired network devices to both sides of the copper CAN bus.
9. Both Network A and B Status LEDs (NSA and NSB) will go on solid on each unit once a valid CAN message is received into either side of the Extender and the baudrate auto-detect has been successfully performed.
10. You may observe the small green LEDs marked RXF and TXF, next to the fiber ports, illuminate when data is received or transmitted.
11. The CAN-Bus Extenders are now operating on the network and they are ready operate in the CAN network.
12. If any of the LED's – marked DGN, NSA and NSB – blink red, this indicates that the internal message buffer on the CANR-DF has been filled before the device could transfer all previously received messages out the other side. Some messages may be lost. Slowing down the scan rate should help eliminate this.

3. General Specifications

Product:	WRC-CANR-DF-DN, Series 3 CAN-Bus Extender and Fiber Optic Converter	
Description:	Electrical Extender to extend the cable distances of CAN-based protocol products and convert the copper network to a fiber optic link.	
Device Type:	Communications Extender	
Product Revision:	3.??	
DeviceNet Conformance:	Designed to conform to the ODVA DeviceNet Specification Volume I, Version 2.0 and Volume II, Version 2.0.	
Baud rate:	125K, 250K, 500K and 1M baud fixed or auto-detect baud rate	
Address selection:	Not applicable	
Bus Connection:	Used On Device:	Woodhead # 1R5006A17A120, male pins, male threads
	CAN-Bus Cable:	See accessories list
Fiber Optic Cable:	62.5/125nm, multi-mode, ST termination	
Fiber Cable Length:	2200 meters (max)	
Fiber Connection:	Used On Device:	ST female
	Fiber Cable:	ST male
Status Indicators:	MS - Module Status:	green/red bi-color LED
	NSA - Copper Network A Status:	green/red bi-color LED
	NSB - Fiber Network B Status:	green/red bi-color LED
	DGN - Diagnostic Data:	green/red bi-color LED
	TXF - Fiber Transmit Active:	green LED
	RXF - Fiber Receive Active:	green LED
Voltage Isolation:	Provided by fiber cable system	
Maximum power:	Voltage:	11 - 25 Vdc
	Current:	160 mA @ 11 Vdc - 70 mA @ 25 Vdc
	Power:	1.8 W
Mounting:	Panel-mount, 4 screws	
Size:	Length:	5.11" (130 mm)
	Depth:	2.27" (57,7 mm)
	Height:	3.70" (94,0 mm)
Operating Temp:	0-70 °C	
Humidity:	0-95% RH, non-condensing	

4. Hardware Installation and Configuration

4.1. Overview

A CAN-Bus Extender is a single device connected to two parts of a single CAN-Bus network. The CANR-DF is a NEMA-4X enclosure and is panel mounted.

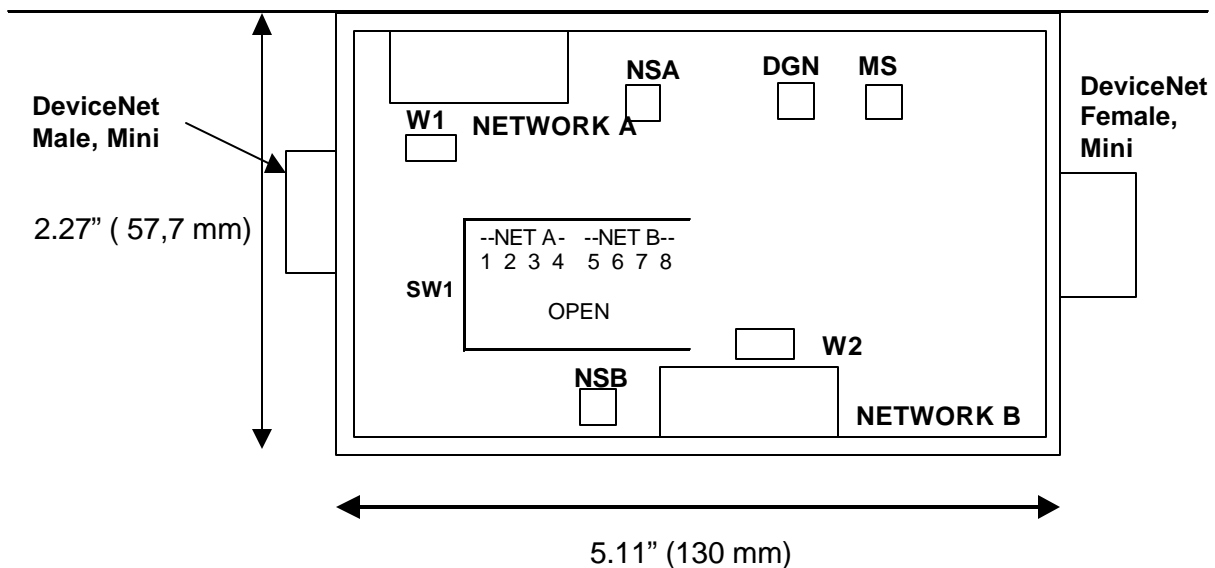

Figure 4-1 WRC-CANR-DF-DN CAN-Bus Extender

4.2. LED Operation

A WRC-CANR-DF-DN Multiplexer has six (6) LEDs that provide visual status information to the user about the product and the DeviceNet network. The LED's definitions are summarized as follows and more thoroughly in the tables below in Table 4-1, Table 4-2 and Table 4-4.

- **MS** – Module Status – indicates the general health of the unit and its ability to Store-and-Forward messages.
- **NSA** – Network Status A – indicates the condition of the CAN bus connection of this Local unit.
- **NSB** – Network Status B – indicates the condition of the Remote unit's CAN bus operation on the other end of the fiber cable.
- **DGN** – Diagnostic – indicates status of the fiber-optic link.
- **RXF** – Receive Fiber – green indicates electrical signals being received by the CANR.
- **TXF** – Receive Fiber – green indicates electrical signals being sent by the CANR.

Table 4-1 Module Status LED (labeled MS)

LED State	Module Status	Meaning
OFF	No Power	There is no power through DeviceNet.
Green	Device Operational	WRC-CANX is operating normally.
Flashing Red	Minor Fault	Advanced Memory Technology (AMT) buffers space exceeded.
Red	Unrecoverable Fault	WRC-CANX may be damaged.
Flashing Red/Green	Device Self-Testing	WRC-CANX is in self-test mode.

Table 4-2 Local Device's Network Status LEDs (labeled NSA)

LED State	Module Status	Meaning
OFF	No Power / Not on-line	WRC-CANX has no power or device is not operating.
Flashing Green	Idle	WRC-CANX has not received a valid message for 0.5 sec.
Fast Flashing Green	Autobaud selection	The WRC-CANX is waiting for a valid message to fix the baudrate.
Green	On-line	WRC-CANX is operating normally and receiving messages.
Flashing Red	CAN controller buffer overflow	There is more traffic on the network than the system can handle.
Red	Critical link failure (Bus Off)	WRC-CANX has detected an error that makes it incapable of communicating on the link.

Table 4-3 Remote Device's Network Status LEDs (label NSB)

LED State	Module Status	Meaning
OFF	No Power / Not on-line	WRC-CANX has no power or device is not operating.
Flashing Green	Idle	WRC-CANX has not received a valid message for 0.5 sec.
Fast Flashing Green	Autobaud selection	The WRC-CANX is waiting for a valid message to fix the baudrate.
Green	On-line	WRC-CANX is operating normally and receiving messages.
Flashing Red	CAN controller buffer overflow	There is more traffic on the network than the system can handle.
Red	Critical CAN link failure (Bus Off)	WRC-CANX has detected an error that makes it incapable of communicating on the CAN bus.

Table 4-4 Diagnostic Status LEDs (labeled DNG)

LED State	Module Status	Meaning
OFF	Normal	Normal operation.
Green	Fiber Link OK	Serial link to fiber network operating.
Red	Time-out	Unit has not received a serial message from the fiber link.
Flashing Red	Communications error	Internal FIFO stack has overflowed on the fiber link interface.

The Green TXF and RXF LED's are illuminated when data is actively transmitted out to the fiber link.

4.3. DIP Switch Settings

The WRC-CANR-DF has an 8-pole DIP switch.

- Switch positions 1-4 are used to set the baud rate of the CANR on which it is located (the local unit).
- Switch positions 5-8 are used to set the baud rate on the CANR at the other end of the fiber cable (the Remote Device).

The baud rates can be set independently, or one side can take its baud rate from the other side (in the "Remote" setting).

Table 4-5 Baud Rate Settings for Switches

Baud rate	Local	Position 1	Position 2	Position 3	Position 4	Meaning
	Remote	Position 5	Position 6	Position 7	Position 8	
125K		CLOSED	CLOSED	CLOSED	CLOSED	Fixed
250K		CLOSED	CLOSED	CLOSED	OPEN	Fixed
500K		CLOSED	CLOSED	OPEN	CLOSED	Fixed
Autobaud		CLOSED	CLOSED	OPEN	OPEN	Autobaud
Remote		OPEN	OPEN	OPEN	OPEN	Takes baud rate from the opposite end device. If both sides are remote, Autobaud from either side.
N/A		ALL OTHER POSITIONS				Reserved for future use

4.4. Power Requirements

The WRC-CANR-DF-DN CAN-Bus Extender subsystem is powered from the 11-25 Vdc provided by the DeviceNet network. The WRC-CANR-DF-DN consumes 70 mA of current at 24 Vdc, or 1.8 Watts, typical. See Section 3.

4.5. CAN Network Cabling and Configuration

This section provides general guidelines for connecting DeviceNet and SDS systems. You can find detailed specifications in the referenced ODVA DeviceNet and Honeywell SDS specifications.

4.5.1. Cable Lengths

The following provide cable length limits for DeviceNet and SDS systems. These numbers apply independently to each physical section of the network, whether it is copper or fiber.

Table 4-6 Network Maximum Lengths - DeviceNet

Baud Rate	Trunk Line Length		Drop Length			
	Maximum Distance		Maximum		Cumulative	
	Meters	Feet	Meters	Feet	Meters	Feet
125 Kbits/s	500 m	1640 ft	6 m	20 ft	156 m	512 ft.
250 Kbits/s	250 m	820 ft	6 m	20 ft	78 m	256 ft.
500 Kbits/s	100 m	328 ft	6 m	20 ft	39 m	128 ft.

DeviceNet has a limit of 64 nodes per network for any baud rate. The CANR-DF is transparent to the network and does not count as an addressed device. However,

Table 4-7 Network Maximum Lengths - SDS

Baud Rate	Trunk Line Length (maximum)		Drop Length (maximum)		No. of Nodes
	Meters	Feet	Meters	Feet	
125 Kbits/s	457.2	1500	3.6	12	64
250 Kbits/s	182.8	600	1.8	6	64
500 Kbits/s	91.4	300	0.9	3	64
1 Mbits/s	22.8	75	0.3	1	32

SDS has a limit of 32 nodes per network for any baud rate. The CANR-DF does not count as an addressed device.

4.5.2. Network Termination

A CAN-Bus system **must be terminated at each end of a copper trunk line**. The host controller and the **last** node device or WRC CAN-Bus Extender on the network must always be terminated to match impedance and eliminate reflections, even if only two nodes are present. Follow the information below when using a CANR-DF.

The CANR Series 3 has a built-in terminator which can selectively included or omitted from the network. To include the on-board terminator (on the DeviceNet side), install jumper W1; or remove the W1 jumper if the on-board terminator is not desired. The CANR is shipped from the factory with the jumper installed. See Figure 4-1 for the location of the jumper.

Trunk line use:

For the purpose of network termination, the CANR-DF is treated as the last node on the copper section of the trunk network (side A) to which it is connected. Therefore, when a CANR-DF is used directly in a trunk line, it must be terminated on side A. The terminating resistor built into the CANR-DF at W1 must be installed, or another terminator at the end of the line could be used in the place of the W1 terminator.

Drop line use:

When CANR-DF is used in a drop line (the Network A side is toward the main trunk), the Network A connection must **not be terminated**. The user must remove the built-in terminator by removing the jumper plug at W1.

Some specifications for the terminating resistor are:

Table 4-8 Terminating Resistors

DeviceNet	SDS
121 ohm	120 ohm
1% metal film	2%
1/4 watt	1/4 watt

Important: Per the DeviceNet and SDS specs -- do not terminate devices on drop lines.

4.5.3. CAN-Bus Connection Wiring

The CANR-DF uses the round, mini-style connector on the copper side A and standard ST connectors on the fiber side B.

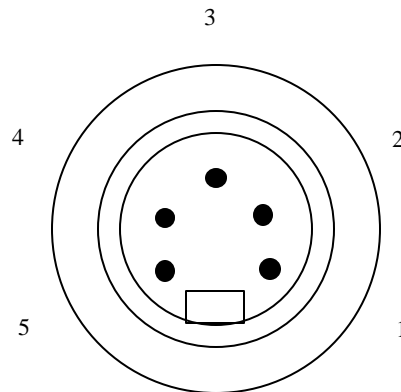

Figure 4-2 **DeviceNet** Network Side A cable connector – Male (pins)

Pin #	Function	Wire color
1	Drain	bare
2	V+	red
3	V-	black
4	CAN_H	white
5	CAN_L	blue

Table 4-9 **DeviceNet** cable specifications

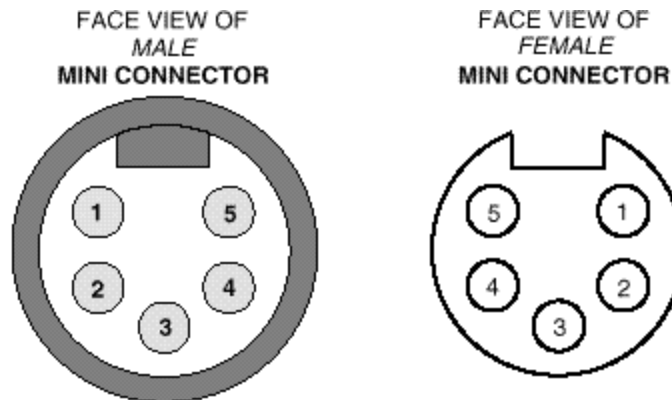

Figure 4-3 **SDS** Mini Connector

Pin #	Function	Wire color
1	Drain	Bare
2	V+	Brown
3	GND	Blue
4	CAN_H	Black
5	CAN_L	White

Table 4-10 SDS cable specifications

4.5.4. Alternate Connector Options

Cable sets may be purchased from an appropriate vendor or custom-made. Turck supplies individual connectors that may be used to build custom DeviceNet or SDS copper cables. Turck part number B 4151-0/16 is a 5-pin, 600V, 9A connector that mates with a number of cables that may be used for the Network A side on the CANR. Contact WRC or your local Turck dealer.

4.6. *Fiber Cable*

The CANR employs fiber optic driver and receiver that is capable of operating 62.5/125 multi-mode cable a distance of 2200 meters. They use ST connectors.

The fiber cables are connected between TX of one CANR and RX of the other.

For custom applications using different fiber cable technology, contact WRC.

5. Operation

Each CANR system receives CAN messages and then packs and transmits the messages over the fiber link to the other CANR, which produces the messages onto its CAN bus network. The CANR pair provides electrical isolation between the two CAN sub-networks. It has no CAN address and is logically transparent to the CAN network protocol. The CANR does not interpret nor act on the CAN messages.

The CAN Bus is connected to the A Side of the CANR-DF and receives its power from the Bus.

Whenever a message is transmitted on the Bus to which the CANR-DF pair is connected, one CANR-DF receives the message on the side where it was initiated and performs a store-and-forward of the message to the other side. This action is performed for any valid CAN message independent of who generated it or to whom it is intended.

There is a propagation delay of the message through the CANR-DF system, consisting of 2 parts: each CANR introduces approximately a 75 μ sec delay, and the transmission time on the fiber link (in both directions) introduces additional delay.

The CANR Series 3 adds the capability for each unit to monitor and report on the status of the other unit in the pair. The NSB LED on one unit reflects the status of the other unit. In this manner you can determine the operating status of both units by observing just one of them.

Also the CANR allows you set up the baud rate for both units from just one. See the section on switch settings, 4.3 above, for more details.

5.1. Application Notes

NOTE: CANR-DF'S ARE ALWAYS USED IN PAIRS!

To help insure ease of installation and reliable operation of your system, the following guidelines should be followed CANR-DF installation in your CAN network.

1. Proper CAN bus termination is critical to reliable operation of the network. Set the SW1 jumpers on the CANR's appropriately.
2. Other than improper terminators, the most common problem is correct fiber cable connection and termination. Make sure one cable connects TX on one to RX on the other and vice versa. Also confirm that the fiber itself is good quality and the ends are correctly polished and terminated with ST connectors.
3. Use the on-board LEDs to help determine the health of the fiber cable interconnection.
4. In Autobaud applications, the baud rate that each device selects will be defined by the first valid message received from either the CAN-Bus or via the fiber connection from the other device.
5. Although multiple CANR's can be used in series, Use only one CANR-DF pair in any network section. That is, only use one CANR-DF pair per trunk line or drop line.
6. CANR-DF is not a grounded device and the Bus shield is not connected electrically to the device. Therefore, follow appropriate wiring practices to eliminate noise and other problems.

Example of a valid drop line applications are shown in the following figures. See Figure 1-1 for an example trunk line application.

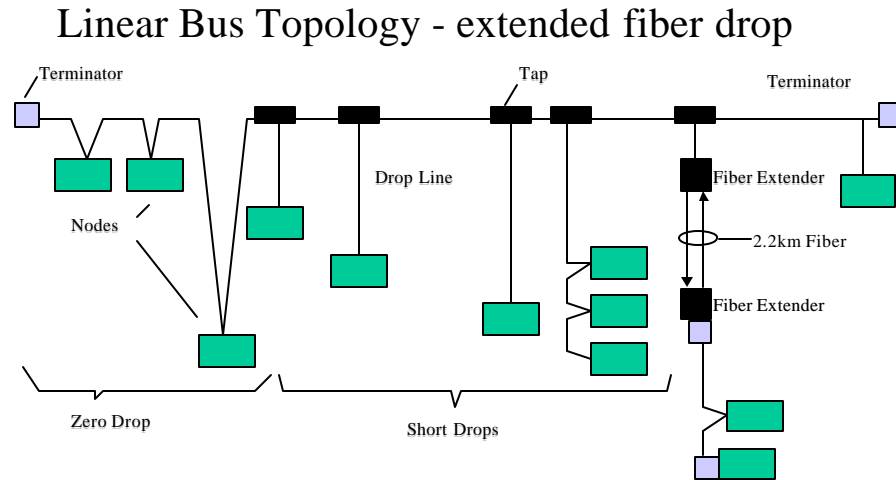

Figure 5-1 CANR-DF on a drop line

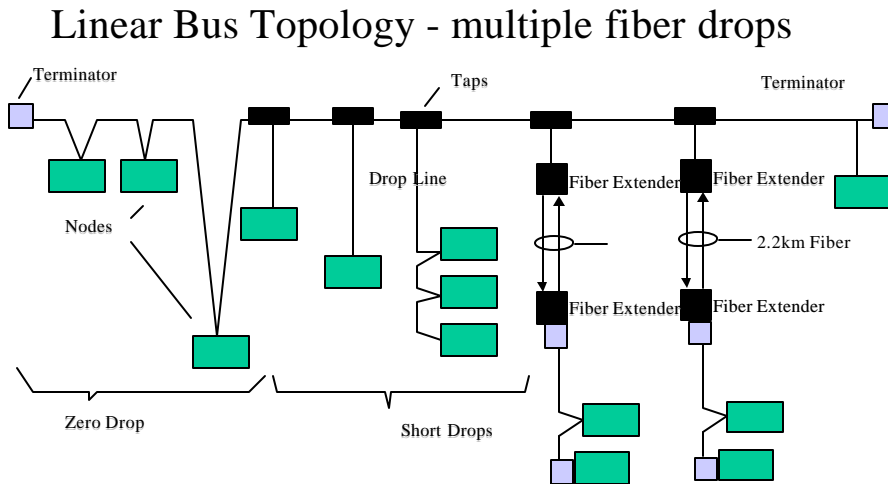

Figure 5-2 CANR-DF on multiple drop lines

6. Accessories and Other WRC Products

The following components can be used with a JDxx for replacements or spare parts, or as complementary devices as a part of your DeviceNet system.

<u>Part</u>	<u>WRC P/N</u>	<u>Equivalent Mfr. Part Number</u>
• CANX-NEM Cable	n/a	Various manufacturers' Mini-Style Connector Examples: Cable assy. w/ male threads, male pins: Turck RSM 570-*M/630 ("trunk line") Turck RSM 571-*M/630 ("drop line")
• DIN rail (1 meter)	WRC 50022	Phoenix Contact NS 35/7,5 0801733 (2 m) Allen-Bradley 199-DR1 (1 m)
• Terminating resistor	RM121DN	121 Ω , 1%, metal film, axial lead resistor

Table 6-1 Accessories and Other WRC Products

Part	WRC Part Number
DIN rail	WRC 50022
Terminating resistor, axial lead	RM121DN
Connector, 5-pin mini-round for CANX, CANR	B 4151-0/16 (Turck)
Discrete I/O block – 4 channels	1782-JDB4
Discrete I/O block – 8 channels	1781-JDB8
Analog Input block – 4 channels, 10-bit	1782-JDA4
Analog I/O block – 8 channels, 12-bit	1782-JDA8
DeviceNet to Serial I/O Gateway	1782-JDC
DeviceNet to Serial I/O Gateway, Enhanced	1782-JDCE
DeviceNet-to-Serial I/O Gateway, 4 channels	W5-JDC4
DeviceNet to Modbus Gateway	1782-JDM
Discrete I/O block – 24 channels	WRC1-JDB24
Discrete I/O block – 48 channels	WRC1-JDB48
Discrete I/O, Analog Input block – 24 DIO, 32 AI	WRC1-JDA/24
Discrete I/O, Analog Input block – 48 DIO, 32 AI	WRC1-JDA/48
Analog I/O block - 32 channels	WRC1-JDAIO
Discrete and Analog I/O block – 24 DIO, 32 AIO	WRC1-JDAIO/24
Discrete and Analog I/O block – 48IO, 32 AIO	WRC1-JDAIO/48
Discrete I/O block – 8 DIs, 8 DOs, 4 AIs	W5-JDB16x
DeviceNet, CANopen Extender, DIN mount	WRC-CANX-DIN-DN
SDS Extender, DIN mount	WRC-CANX-DIN-SD
DeviceNet, CANopen Extender, DIN mount	WRC-CANX-DIN-C7
DeviceNet, CANopen Extender, NEMA box	WRC-CANX-NEM-AU
DeviceNet, CANopen Extender, NEMA box	WRC-CANX-NEM-DN
SDS Extender, NEMA box	WRC-CANX-NEM-SD
DeviceNet, CANopen Extender, Fiber Optic, NEMA box	WRC-CANR-DF-DN

7. Troubleshooting

This section identifies some of the common problem observed when commissioning or operating a CANR-DF Extender.

Problem:

DeviceNet devices will not communicate on the network
Module Status LED is solid Green
Network Status LEDs are flashing Green at 1/2second intervals

Meaning

No transmissions have been received by the CANX for 0.5 seconds.

Possible Solutions:

1. Network cables are broken or disconnected.
2. Network is not properly terminated.
3. All devices have stopped trying to communicate on the network.
4. Power has been lost on the B Side subnetwork.

Problem:

DeviceNet devices will not communicate on the network
Module Status LED is solid Green
Network Status LEDs are flashing Green quickly

Meaning

The CANX is in autobaud and is waiting for a valid message to fix its baud rate.

Possible Solutions:

1. Network cables are broken or disconnected.
2. Network is not properly terminated.
3. All devices have stopped trying to communicate on the network.

Problem:

Some messages are missed on network.
Module Status LED is solid Green
NSA and NSB LEDs are flashing Red

Meaning

Internal CAN buffers are full. Network has more traffic than it can handle.

Possible Solutions:

1. Reduce the scan rate from the Master.
2. Reduce the COS frequency on I/O devices.
3. Decrease the assembly sizes of I/O connections.
4. Recalculate the network traffic and bandwidth without the CANX.

Problem:

Some messages are missed on network.
Module Status LED is flashing Red

Meaning

Internal AMT buffers are full. Network has more traffic than it can handle.

Possible Solutions:

1. Reduce the scan rate from the Master.
 2. Reduce the COS frequency on I/O devices.
 3. Decrease the assembly sizes of I/O connections.
 4. Recalculate the network traffic and bandwidth without the CANX.
-

Problem:

Device will not communicate on the network
Module Status LED is solid Green
Network Status LED is flashing Green

Possible Solutions:

1. CANR does not see CAN messages on the network.
2. Network does not have a terminating resistor. Add a 121 ohm resistor across the CAN_H and CAN_L signals at the first and last nodes.
3. Network cable is broken or disconnected.
4. Network cable is miswired.

Problem:

Device will not communicate on the network
DGN is solid red or off

Possible Solutions:

1. Fiber Link is broken or not connected
2. Rerterminate, Replace or Reconnect the optical fiber.

8. Summary of Changes to Series 3 from Rev 2

To facilitate implementation of the new Series 3 CANR products for customers that are currently users of the CANR Revision 2.xx products, this section summarizes the product changes from Rev 2 to Series 3.

8.1. *DIP Switch Baud Rate Settings*

Several new options exist for setting the baud rate on the CANR Series 3.

- The Series 3 has an 8-position DIP switch block. All 8 switches are defined and used.
- Both sides' baud rates can be set up independently.
- A "remote mode" exists which allows either side to set its baud rate based on the other side's BR – in either fixed baud or autobaud.
- See Section 4.3 for details.

8.2. *Indicator LED's*

The definition of some states of the LEDs have changed. Refer to Section 4.2 for details.

8.3. *Terminating Resistors*

The Series 3 has an on-board terminating resistor on the CAN connection that can be selectively included or excluded from the network circuit. With jumpers W1, the CANR puts a 121-ohm resistor across the CAN_H and CAN_L lines on sub-network side A. See Section 4.5.2 and Table 4-8 for the location of this jumper.

8.4. *Operation and Functionality*

The previous version CANR required one Type 1 and one Type 2 unit per connection. The Series 3 products now make no differentiation – there is only one design. Therefore, you do not need to be concerned with "matching pairs".

Important: The Series 3 product is not backwards compatible with the previous versions.

You cannot implement a network which consists of a Revision 2 product on one end of the fiber and a Series 3 on the other end.

8.5. *2.2km Fiber Link and Diagnostics*

The CANR has the following fiber serial link improvements:

- Extends your applications for up to 2.2km at any CAN baud rate.
 - This significantly increases opportunities for mining, tank farm, remote out-buildings, and other similar applications.
- Additional diagnostics:

- A “heartbeat” feature has been added to the fiber link. A heartbeat message is generated between the 2 CANR units when no CAN activity is present for approximately 0.5 sec, allowing each unit to confirm the status of the link.
- The NSB LED indicates the health of the fiber connection for both normal traffic and the heartbeat.

8.6. Enhanced CAN Support

The CANR now supports CAN 2.0 Part B, as well as Part A. It also can operate up to 1M Baud. (See factory for details.)

8.7. Field Programmable Updates

The CANR Series 3 has its program held in flash memory, which can be updated in the field. Contact the factory for details.