

SINKING

INPUTS: Relay Ladder Representation

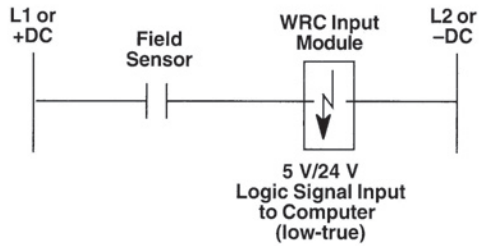

SOURCING

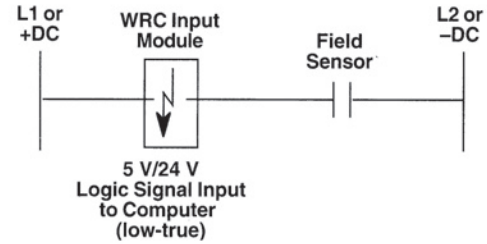

INPUTS: Schematic Representation

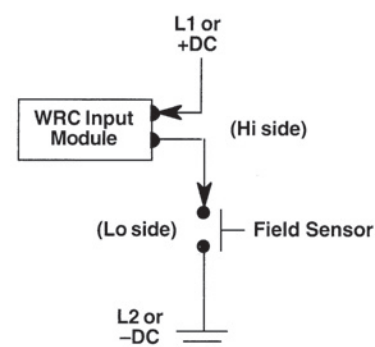
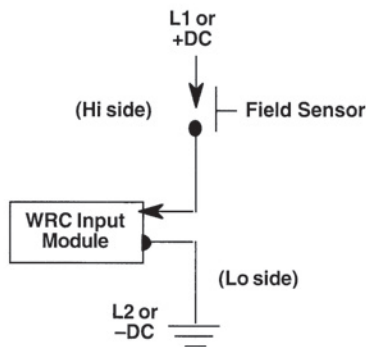

OUTPUTS: Relay Ladder Logic Representation

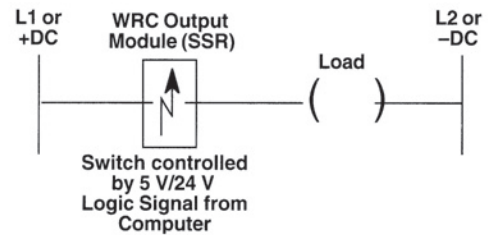
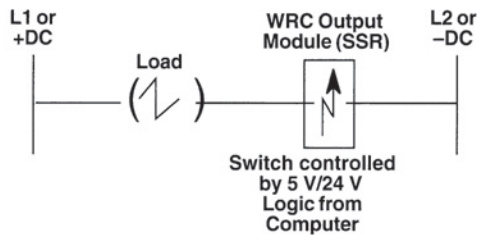

OUTPUTS: Schematic Representation

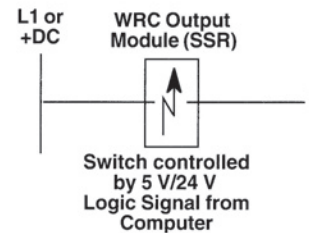
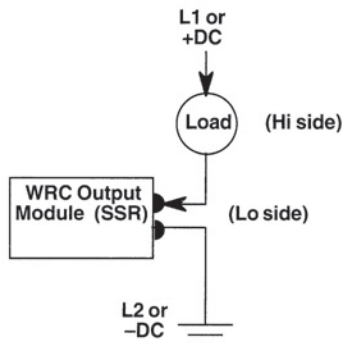

Sinking means the module “sinks” or receives the voltage/current supplied through other devices in the circuit. For outputs this is sometimes called a “low-side” or “neutral-side” switch.

Sourcing means the module “sources” or supplies the voltage/current to other devices in the circuit. For outputs this is sometimes called a “high-side” or “hot-side” switch.

SINKING e.g. 1781-IT5Q

INPUTS: Relay Ladder Representation

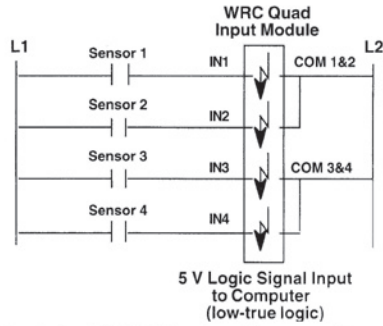

SOURCING e.g. 1781-IB5Q and 1781-OB5Q

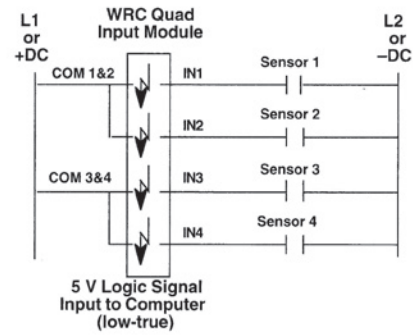

INPUTS: Schematic Representation

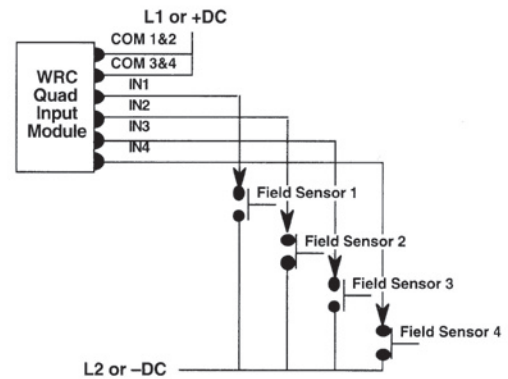
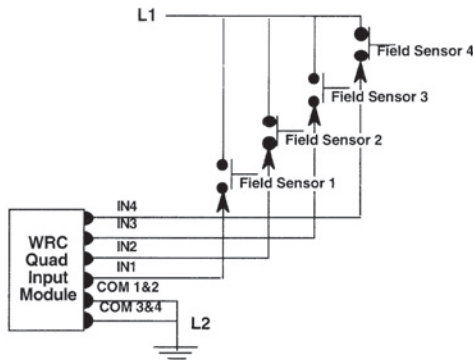

OUTPUTS: Relay Ladder Logic Representation

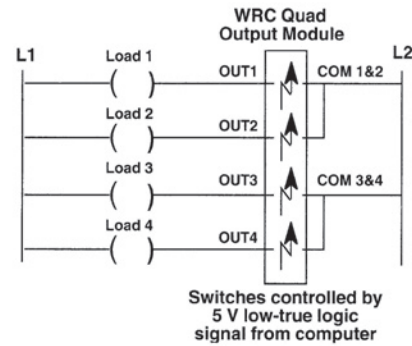
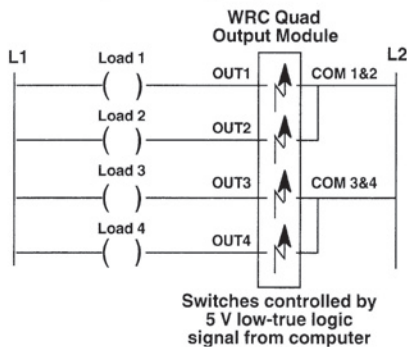

OUTPUTS: Schematic Representation

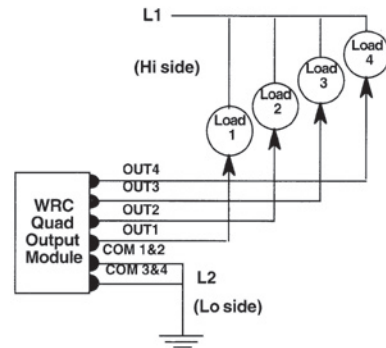
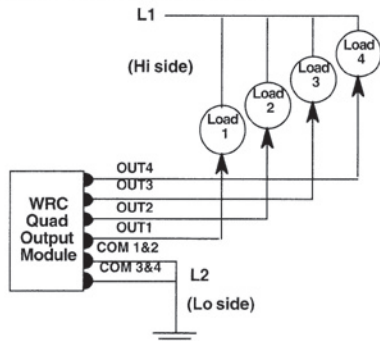

Sinking means the quad module “sinks” or receives the voltage/current supplied through other devices in the circuit. For outputs this is sometimes called a “low-side” or “neutral-side” switch.

Sourcing means the module “sources” or supplies the voltage/current to other devices in the circuit. For output, this is sometimes called a “high-side” or “hot-side” switch.